



**SOLAR WARNING and OBSTRUCTION LIGHTS FOR AVIATION**



- Applications :**  
 Wind Mills  
 Bridges  
 Buildings  
 Lighthouses  
 Cooling Towers  
 Chimneys  
 Cranes  
 Telecommunication Towers  
 Transmission Line Towers  
 Wind Cones  
 Turbines  
 Offshore Oil and Gas Platform  
 Airports etc..

**Housing materials: polycarbon and aluminum alloy**  
**With pressure and abrasion resistance**  
**Warning or signal on tower, TV station and airport**  
**Uses clean and eco-friendly solar power**  
**Easy for installation**  
**No wire needed**  
**Automatically turn on and off by photo sensor**



LED type silicon solar-powered aviation obstruction light mainly consists of a durable plastic lens, a flasher, aluminium alloy cell box and fixture, maintenance-free storage cells and a physical silicon solar panel.

The plastic lens is a fresnel lens moulded with polypropylene acid plastics. This kind of lens has excellent light transmittance and is anti-sunbeam-aging. The flasher utilizes quality electronic components to form the light-control switch which controls the imported super long-life LED chip to give off bright flash light. The lifetime of LED is 20years.

The perfect combination of high-efficiency physical silicon solar panel and high-capacity storage cells provides adequate power for the flasher to keep flashing for 15-20 days continuous overcast and rainy days. This product doesn't require any maintenance for 3 years if used in normal conditions.

Light intensity >4000cd

Model	ATL-SOL70	ATL-SOL90	ATL-SOL123
Plastic lens	70mm	90mm	123mm
Working voltage	DC : 12V(+/-)20%		
Static current	10mA		
flash frequency	20~60 times/min (adjustable)		
Lighting color	RED, GREEN, BLUE, WHITE, ORANGE(RED is normal)		
Lighting range/ visibility	>5Km(T=0.95) - +5000 Mts		
light control sensitivity	200LX(adjustable)		
storage cell capacity	12V7AH	12V12AH	12V7AH
Lighting under overcast and rainy weather	18days	20days	15days
Working environment	-40℃~+70℃		
level of protection	IP65		
Bottom installation specification	Max circle Φ180 , pitch circuleΦ150mm, Average 8-Φ10mm hole		
Lamp net weight	8 kg	12kg	8 kg

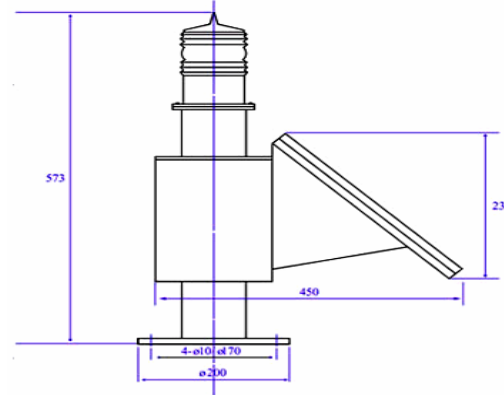

Number of obstruction lights to be placed on tall structures can be calculated by the following formula -  
 Number of Lights = N = Y/45  
 Where Y is the height of the Obstruction.  
 Light spacing = X = Y/N <= 45m  
 There should be atleast 45 meter gap between two obstruction lights installed on tall structures.

